

SwitchBlade Deflector™ Windshield
Lexan® polycarbonate with QUANTUM™ Coating
This installation manual covers Kit UQ01, Kit UQ05 and Kit UQ07

Dealers: If installing this windshield for a customer, please give them this manual. It contains information needed to properly maintain and use this product.

The SwitchBlade Deflector is intended for use with the correct QuickSet 4™ mount kit for your motorcycle. At any time you may interchange windshields with the 2-Up™ or Shorty™ using the same mount kit. *All Patents Pending*

Attention



Special notes and cautionary measures which can prevent damage to the accessory or motorcycle.

Note:



Tips for facilitation of operation, control and adjustment, as well as maintenance work.

Parts List For: Kit UQ01, Kit UQ05, Kit UQ07

Note: Your specific Mount Bracket number is specified in Index 1 and 2.



The items pre-assembled to the windscreen are properly tightened using thread lock. Do not adjust.

INDEX	PART NO. AND DESCRIPTION	QTY.
1	37-371931-000 Mount Bracket, Left KIT UQ01	1
1	37-371935-000 Mount Bracket, Left KIT UQ05	1
1	37-371937-000 Mount Bracket, Left KIT UQ07	1
2	37-371932-000 Mount Bracket, Right KIT UQ01	1
2	37-371936-000 Mount Bracket, Right KIT UQ05	1
2	37-371938-000 Mount Bracket, Right KIT UQ07	1

BAG 761 Contained in KIT UQ01, UQ05, UQ07

3	55-586043-000 Bolt, Carriage 5/16"-18 x 5/8"	4
4	42-482201-000 Nut, Hex Cap 5/16 - 18	4

Preparation

Position the motorcycle securely on its stand or a work stand. Cover the front fender and fuel tank with a suitable cloth to avoid scratches from dropped tools.



Left and right side of motorcycle and product are determined while sitting on the bike.



1, 9/16" Socket
 1, Socket Wrench

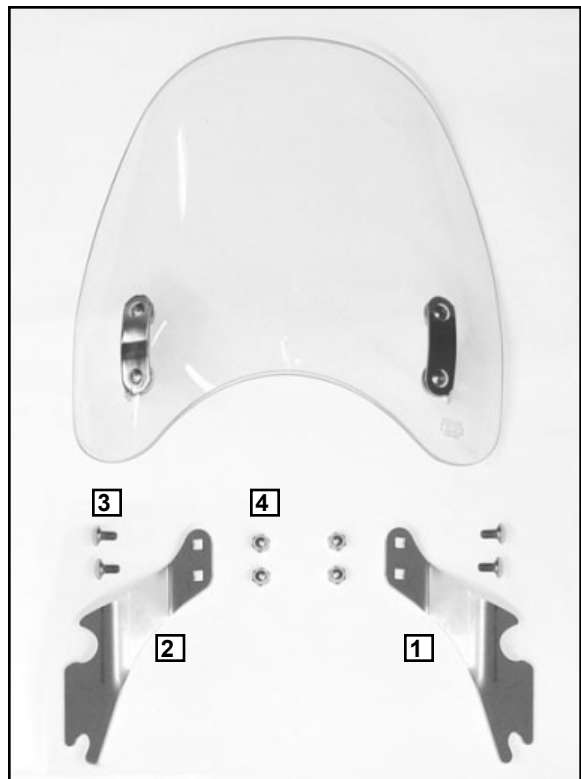



Figure 1.

INSTALLATION
ATTACH THE BRACKETS TO THE WINDSHIELD

 When properly identified and installed, Bracket bends outboard. Bracket mounts outboard to the pre-assembled windshield mount as well.

1. Identify right side Bracket (2).
2. Assemble right Bracket to right side of windshield with Carriage Bolts (3) and Nuts (4). Be certain Bolt neck seats correctly in Bracket. **(9/16 Socket and Wrench) Figure 2.**

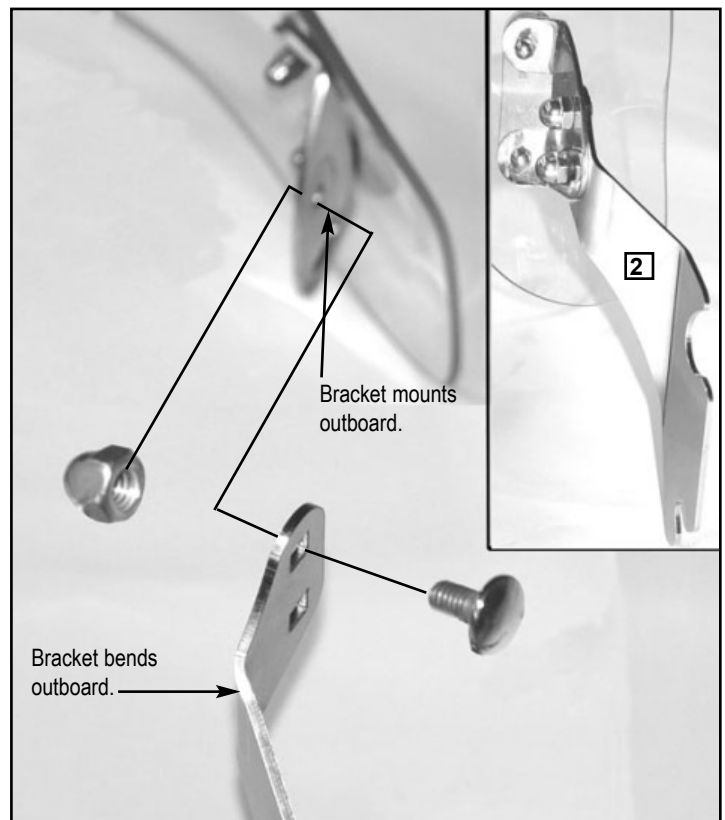

Figure 2. Right Side Bracket Assembly

ADJUST BRACKETS, TIGHTEN TO "HOLD"

3. Repeat on left side. For now, adjust Brackets so notched edge is perpendicular to the ground and screen has a slight rake. Tighten to hold. **Figure 3.**

INSTALL WINDSHIELD TO MOTORCYCLE, ADJUST AND TIGHTEN SECURLY

4. Refer to the SwitchBlade Owner's Manual attached to the windshield and install shield to motorcycle. Make final adjustments to rake and tighten Nuts (4) firmly (15 ft/lbs.) **(9/16 Socket and Wrench)**

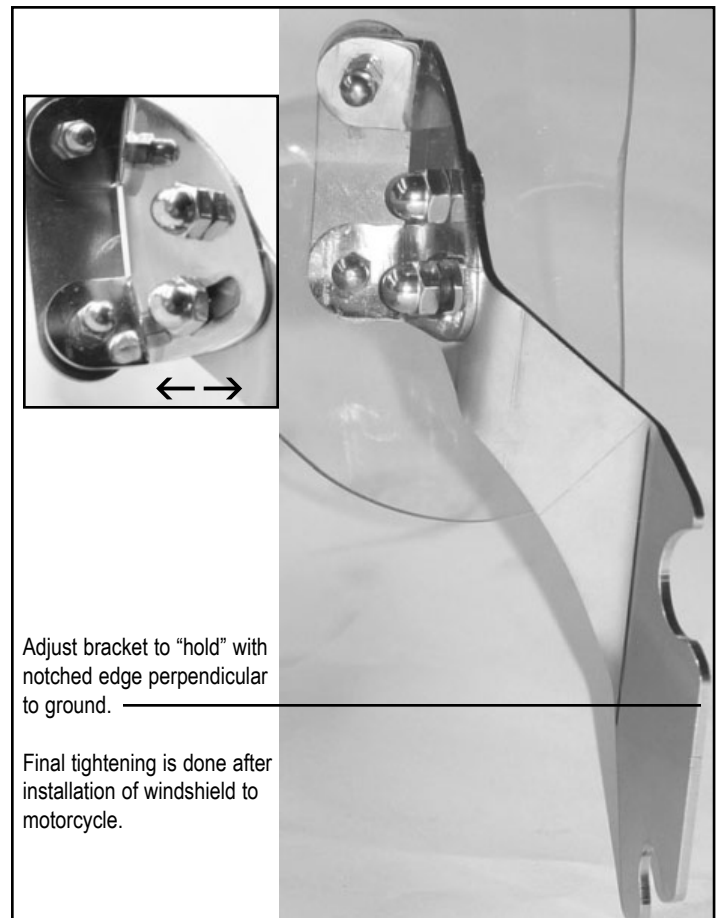

Figure 3.

Mount Kit Q102 or Q106 for installation with SwitchBlade Windshields: 2-UP®, Chopped™ Shorty™ or Deflector™

Dealers: If installing the Quick Release mount kit for a customer please give them this manual. It contains information needed to properly maintain and use this product.

The Quick Release mount kit will allow you to mount any of the four styles of SwitchBlade windshields to the motorcycle this kit is installed on. Contact your dealer or National Cycle for complete information for all three SwitchBlade Windshields: **2-UP®, Chopped™ Shorty™ or Deflector™** Patents: 6254166, 6484914, 6974175

Attention



Special notes and cautionary measures which can prevent damage to the accessory or motorcycle.

Note:



Tips for facilitation of operation, control and adjustment, as well as maintenance work.

Parts List For Kit Q102

INDEX	DESCRIPTION	QTY.
1	37-379102-000 Mounting Cup, Chrome	2
2	34-340501-000 Nut, Upper, QS4, Polished	2
3	34-340502-000 Nut, Lower, QS4, Polished	2
4	34-340510-000 Spool, Upper, QS4, Assembled	2
5	34-340512-000 Spool, Lower, QS4, Plain	2
6	49-490414-000 Washer, Brass	2
7	37-370170-000 Clamp Strap, QS4	4
8	37-370160-TL0 Spider, QS4 w/ Thread Locker	2

Parts List For Kit Q106

INDEX	DESCRIPTION	QTY.
1	37-379102-000 Mounting Cup, Chrome	2
2	37-340501-000 Nut, Upper, QS4, Polished	2
3	37-340502-000 Nut, Lower, QS4, Polished	2
4	34-340510-000 Spool, Upper, QS4, Assembled	2
5	34-340512-000 Spool, Lower, QS4, Plain	2
6	49-490414-000 Washer, Brass	2
7	37-370184-000 Clamp Strap, QS4	4
8	37-370161-TL0 Spider, QS4 w/ Thread Locker	2



1, Hex Key Wrench, 4mm
1, Torque Wrench that accurately measures 75 inch pounds. (6.25 ft/lbs) (8.6 Nm)

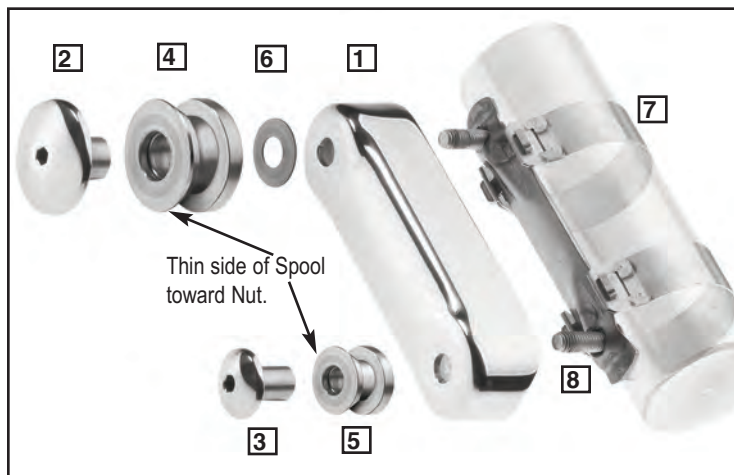

Figure 1.

Preparation



Proper tightening of this assembly is critical. Use a Torque Wrench!

Follow this procedure! Correct assembly of this kit will provide years of reliable service.

Position the motorcycle securely on its stand or a work stand. Cover the front fender and fuel tank with a suitable cloth to avoid scratches from dropped tools.

INSTALLATION

ATTACH THE SPIDER TO THE FORK

1. Place two Clamp Straps (7) on the fork tube.
2. Hook the Spider (8) to the lower Clamp Strap. **Figure 2.**
3. Install the upper Clamp Strap.
4. Position the Mounting Cup (1) onto the Spider Bracket so the studs protrude from the holes in the Mounting Cup. **Figure 1, page 1.**
5. Place a Brass Washer (6) onto the top stud. **Figure 1.**
6. Push the large Upper Nut (2) into the large Upper Spool (4) so the **thin side** of the spool is near the head of the Upper Nut. **Figure 1.**
7. Start the Upper Nut/Spool onto the upper stud. **(4mm Hex Key)**
8. Assemble the Lower Spool (5) and Lower Nut (3) so the **thin side** of the Spool is near the head of the Lower Nut.
9. Start the Lower Nut/Spool onto the lower stud. **(4mm Hex Key)**
10. Repeat steps 1 through 9 on the other fork.

ALIGN THE QUICK RELEASE ASSEMBLY

11. Adjust top edge of Mount Cup to be 3/4" (19mm) from the upper triple clamp. **See Figure 3.**



Depending on the motorcycle this may vary. Adjust windshield so shield clears the headlight when you remove windshield.

12. Adjust both Mounting Cups front to rear so they are in line across the forks.



Misalignment can cause damage to fuel tank and will cause the system to not work properly. Check alignment carefully. Turn the fork carefully to the stops. Make sure the gap between the Spools and the fuel tank are the same on both sides. .

13. Tighten the Nuts to 75 INCH POUNDS (8.6 Nm) (6.25 ft/lbs). **Figure 4. (Torque Wrench, 4mm Hex Wrench.)**



This assembly will not "feel" like tightening a normal nut and bolt. Tightening from 50 in/lbs to 75 in/lbs will take at least one full turn.

14. Refer to the instructions packaged with the SwitchBlade windshield. Install the shield. Make sure all components line up.



15. Cycle the shield through the mount and dismount 5 times.



16. Retighten the Nuts to 75 INCH POUNDS (8.6 Nm) (6.25 ft/lbs).



Figure 4.

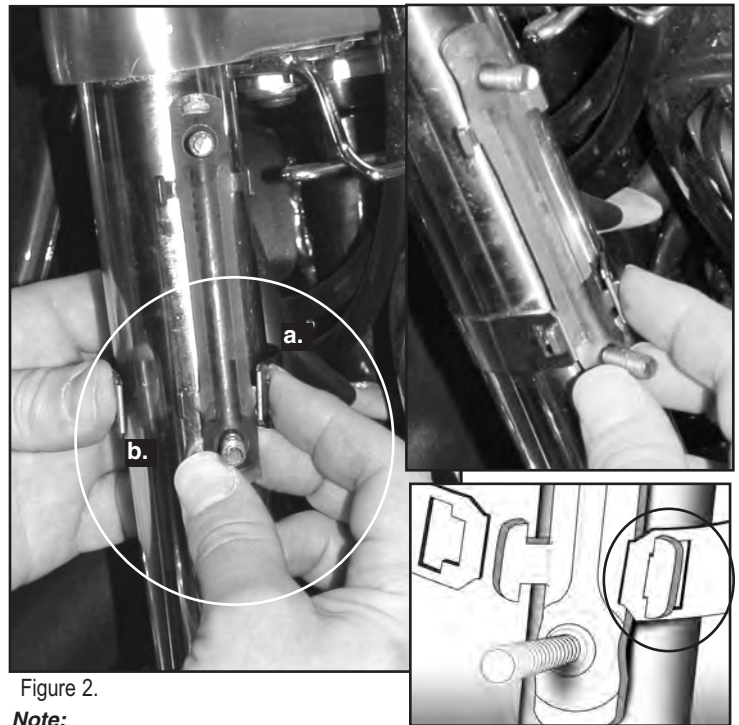

Figure 2.

Note:

Engage the inside of the strap to the spider. Be sure spider hook is fully and correctly seated into the slot.

- a. The technique requires you to keep the hook of the spider **correctly** engaged in the slot. To do this, apply pressure on the inside engaged strap with your index finger while lifting the spider slightly with your middle finger.
- b. Engage strap to hook of spider on outside. Push and stretch with your thumbs, don't let the inside hook/slot become loose.

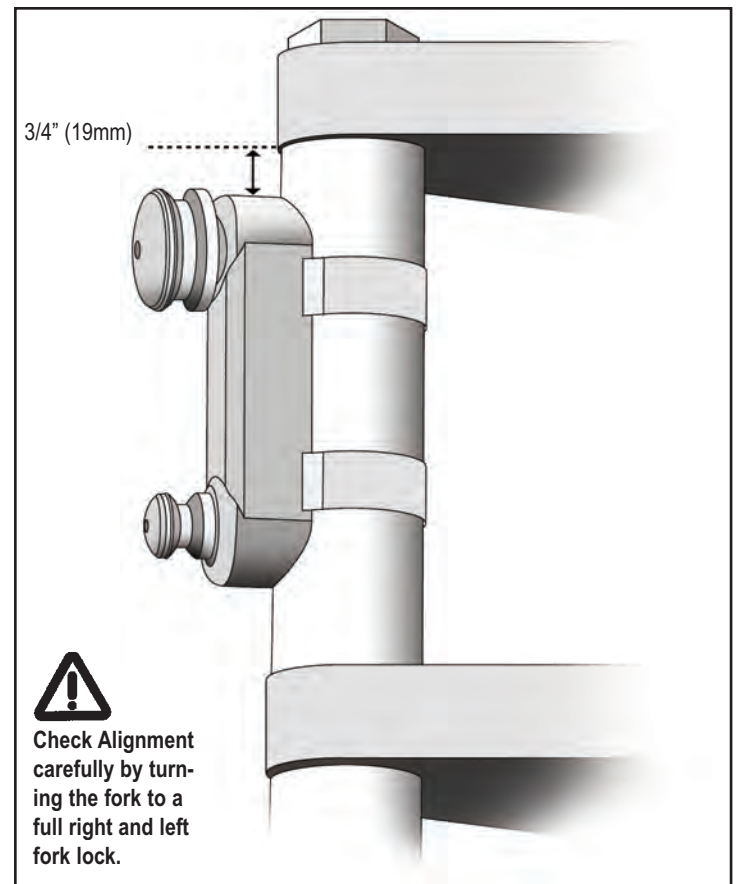

Figure 3.

Check Alignment carefully by turning the fork to a full right and left fork lock.